

REVISIONS			
REV	DESCRIPTION	DATE	APPROVED
A	INITIAL RELEASE	1/30/04	

INSERT "B"
CUTTING EDGE .005
BELOW CENTER
AND CUTTING TO
Ø.820

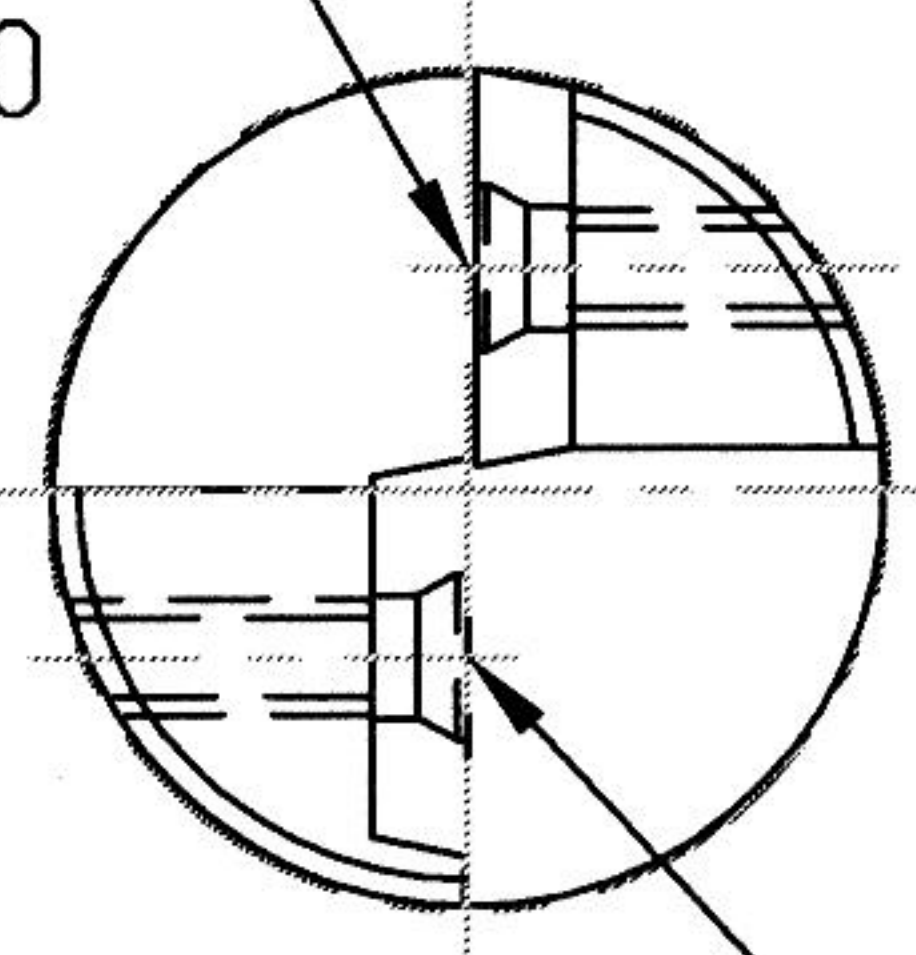

INSERT "A"
CUTTING EDGE ON
CENTER
AND CUTTING TO
C/L OF PART

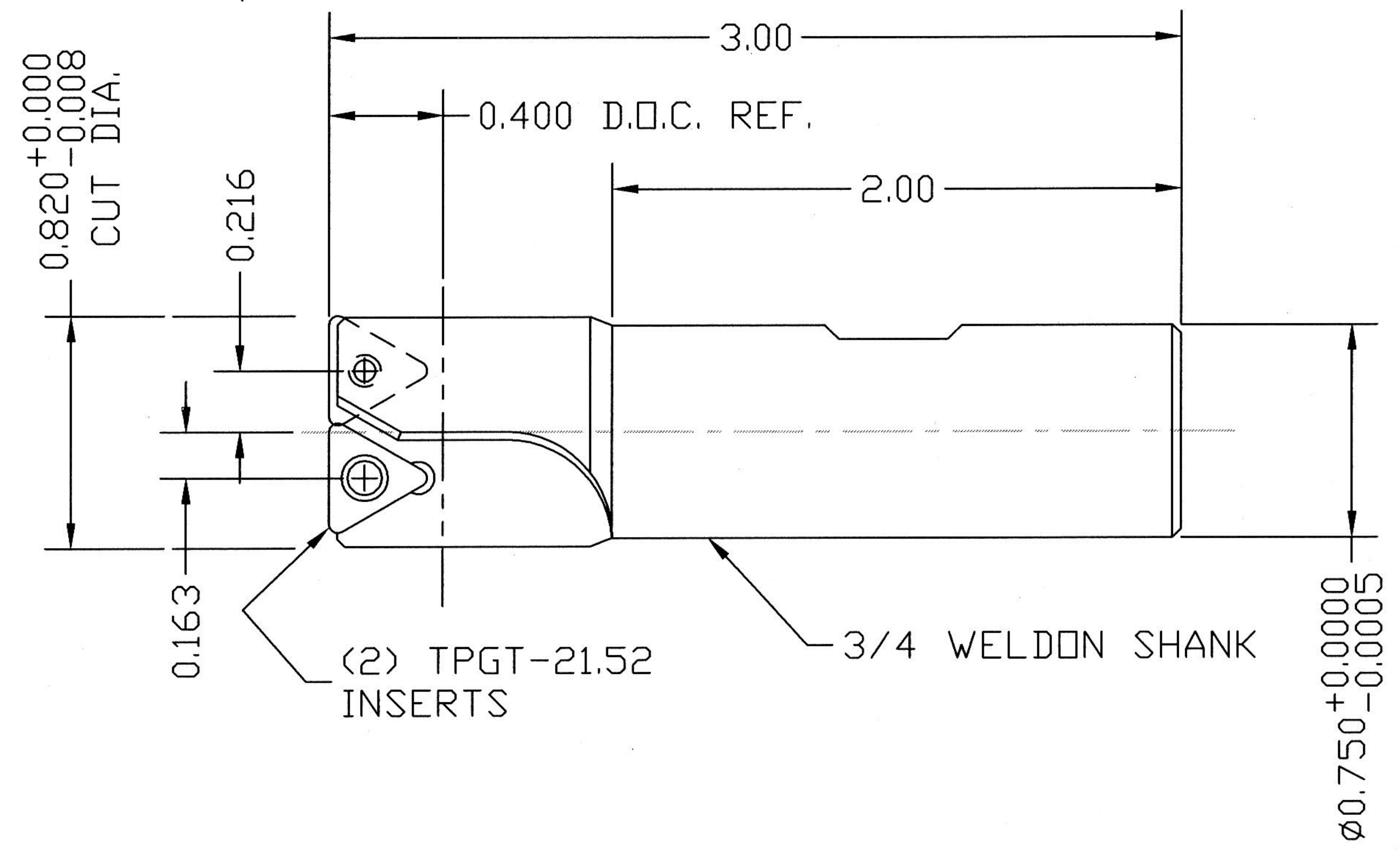

NOTE:
1. CUTTING 12L14 STEEL
2. FOR R.H. ROTATION

GENERAL TOLERANCES, UNLESS NOTED	
.XX DECIMALS	±.010
.XXX DECIMALS	±.005
.XXXX DECIMALS	±.0005
SURFACE FINISH	63 ✓
ANGLES	±1°
BREAK ALL EDGES	.010 X 45°
UNLESS OTHERWISE SPECIFIED	

MTP ASSOCIATES SANDWICH, MA		
DWG. NO: SID1901		
REV. A	DR. BY: A.J.O.	DATE: 1/30/04
TITLE: SPECIAL INDEXABLE DRILL		
MATERIAL: 4140 STEEL		

